



DATASHEET

RF220SU Module

©2024 Synapse Wireless, All Rights Reserved. All Synapse products are patent pending.

Synapse, the Synapse logo, SNAP, and Portal are all registered trademarks of Synapse Wireless, Inc.

Doc# 116-111507-012-E003

351 SW Electronics Blvd, Suite D // Huntsville, AL 35824 // (877) 982-7888 // SynapseWireless.com

SNAP Engine RF220SU Module Overview

The **SNAP Engine Model RF220SU** is an IEEE 802.15.4, low-power, highly reliable solution for embedded wireless control and monitoring networks.

The **RF220SU** embeds Synapse's **SNAP OS**, a wireless mesh network operating system, into the Atmel Atmega128RFA1 single-chip AVP® microcontroller with an integrated transceiver that delivers up to 2Mbits/sec. This low-cost module can have current consumption under 390nA to enable a new generation of battery-driven systems.

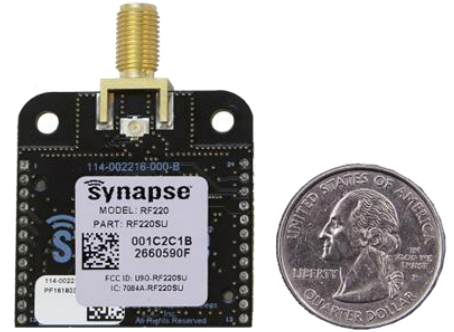

The **RF220SU** also includes a Skyworks SE2431L front-end module, which provides a power amplifier and LNA for increased range.

SNAP's on-board Python interpreter provides for rapid application development and over-the-air programming. The modules provide upto15 channels of operation in the ISM 2.4GHz frequency band.

By default, the **SNAP** operating system automatically forms a mesh network with other nodes immediately on receiving power. No further configuration is necessary. Multiple unrelated **SNAP** networks can exist within the same area through several configuration options outlined in the **SNAP** documentation available from developers.synapsewireless.com.

NOTE: Channel 15 is receive-only due to FCC power restrictions.

This data sheet covers part number RF220SU:

- 20 GPIO with upto7 A/D inputs
- 128k flash, 58.5k free for over-the-air uploaded user apps
- Two UART ports for control or transparent data
- Low power modes:
 - Timed Sleep Mode 1 :1.27 μ A
 - Timed Sleep Mode 2 :1.47 μ A
 - Untimed Sleep Mode :< 390 nA
- Spread Spectrum (DSSS) technology
- Upto2 Mbps radio data rate
- 2.4 GHz RF Frequency
- AES 128-bit encryption
- RP-SMA Antenna or U.FL connector
- Solder-able or socket-able

- 4K internal EEPROM
- 6 PWM outputs
- Supports over the air firmware upgrades.
(This process is further defined in the Portal User Guide.)

Specifications

Table 1.1: RF220SU Specifications at 23° C and 3.3V unless otherwise noted

Performance	Outdoor LOS Range	Up to 1 mile at 250 Kbps using a 5.5dBi antenna
	Transmit Power Output	up to +20 dBm
	RFData Rate	250Kbps, 500Kbps, 1Mbps, 2Mbps
	Receiver Sensitivity	-103 dBm (1% PER, 250Kbps)
Power Requirements	Supply Voltage	2.0 - 3.6 V
	Transmit Current (Typ@3.3V)	at +20 dBm: 150 mA at +6 dBm: 55 mA
	Idle/Receive On (Typ@3.3V)	22 mA
	Idle/Receive Off (Typ@3.3V)	7.8 mA
	Sleep Mode Current (Typ@3.3V)	Timed Sleep: 1.27 μ A Untimed Sleep Mode: 390 nA
General	Frequency	ISM 2.4 GHz
	Spreading Method	Direct Sequence (DSSS)
	Modulation	O-QPSK
	Dimensions	33.86mm x 33.86mm
	Operating Temperature	- 40 to 85 deg C.
	Antenna Options	U.FL and RP-SMA
	Weight	9 grams
Networking	Topology	SNAP
	Error Handling	Retries and acknowledgement
	Number of Channels	15 channels. To avoid exceeding FCC limits, channel 15 operates in a receive only state.

Available I/O	UARTS with optional HW Flow Control	2 Ports
	GPIO	20 total; 7 can be analog-in with 10bit ADC
Agency Approvals	FCC Part 15.247	U90-RF220SU
	CE Certified	The RF220SU-EU is certified to EN300 328 Version 1.8.1
	Industry Canada (IC)	7084A-RF220SU

RF220SU Module Pin Definitions

For pin locations, consult *RF220SU Mechanical Drawing* on page 5 later in this document.

Table 1.2: RF220SU Pin Assignments

RF220SU Pin	Pin Name	SNAPpy IO	ATmega128RFA1 Pin Name	Pin Description
1	GND		GND	Power Supply
2	GPIO0	7	PB7_OC0A_OC1C_PCINT7	IO or PWM or Interrupt
3	GPIO1	6	PB6_OC1B_PCINT6	IO or PWM or Interrupt
4	GPIO2	5	PB5_OC1A_PCINT5	IO or PWM or Interrupt
5	GPIO3	16	PE0_RXD0_PDI_PCINT8	IO or UART0 Rx or Interrupt
6	GPIO4	17	PE1_TXD0	IO or UART0 Tx
7	GPIO5	20	PE4_CTS0_OC3B_INT4	IO or UART0 CTS Output or PWM or Interrupt
8	GPIO6	21	PE5_RTS0_OC3C_INT5	IO or UART0 RTS Input or PWM or Interrupt
9	GPIO7	10	PD2_RXD1_INT2	IO or UART1 Rx or Interrupt
10	GPIO8	11	PD3_TXD_INT3	IO or UART1 Data Out or Interrupt
11	GPIO9	12	PD4_CTS1_ICP1	IO or UART1 CTS output or Input Capture
12	GPIO10	23	PE7_RTS1_ICP3_INT7_CLK0	IO or UART1 RTS input or Clock Output Buffer or Interrupt
13	GPIO11	24	PF0_ADC0	IO or Analog0
14	GPIO12	25	PF1_ADC1	IO or Analog1 or software SPI MOSI
15	GPIO13	26	PF2_ADC2_DIG2	IO or Analog2 or software SPI CLK1 or Antenna Diversity Control

RF220SU Pin	Pin Name	SNAPpy IO	ATmega128RFA1 Pin Name	Pin Description
16	GPIO14	18	PE2_XCK0_AIN0	IO or software SPI1 MISO or Analog Comparator or External Clock
17	GPIO15	28	PF4_ADC4_TCK	IO or Analog4 or JTAG Test Clock
18	GPIO16	29	PF5_ADC5_TMS	IO or Analog5 or JTAG Test Mode Select
19	GPIO17	30	PF6_ADC6_TDO	IO or Analog6 or JTAG Test Data Out or software I ² C SDA
20	GPIO18	31	PF7_ADC7_TDI	IO or Analog7 or JTAG Test Data In or software I ² C SCL
21	VCC		VCC	Power Supply
22	GPIO19	19	PE3_OC3A_AIN1	IO or Analog Comparator or PWM or Output Compare Match
23	RESET#		RESET#	Module Reset, Active Low
24	GND		GND	Power Supply

Electrical Characteristics

Unless otherwise specified in this document, all electrical characteristics conform to the Atmel ATmega 128RFA1 microcontroller. Detailed specifications on all electrical characteristics are available on the Atmel website at <http://www.atmel.com/>

Table 1.3: RF220SU DC Characteristics at 25° C

Symbol	Parameter	Condition	Min	Typ	Max	Units
V _{CC} ¹	Supply Voltage		2.0	3.3	3.6	V

Table 1.4: ADC Electrical Characteristics (Operating)

Symbol	Parameter	Condition	Min	Typical	Max	Unit
V _{REFH} ²	ADC Voltage Reference, High	Programmable	1.5	1.6	1.8	V
V _{INDC}	Analog input voltage	Single Ended	0		1.8	V

¹Absolute maximum stress rated voltage for VCC is -0.3 to 3.6. It is recommended that bulk capacitance be located as close as possible to the VCC pin on the host board. Ideally, use a single 47µF capacitor rated at 10V directly at the VCC pin.

²VREFH is programmable to three fixed values; 1.5V, 1.6V, and 1.8V. The VREFH value will be 1.6 volts if you do not explicitly adjust it by poking the ATmega128RFA1 registers.

Symbol	Parameter	Condition	Min	Typical	Max	Unit
		Differential ³	0		3.3	

Mechanical Drawings

RF220SU Mechanical Drawing on page 5 and *Block diagram showing the major subsystems comprising Model RF220SU* on page 6 are for modules with the compact F antenna and U.FL Connector options.

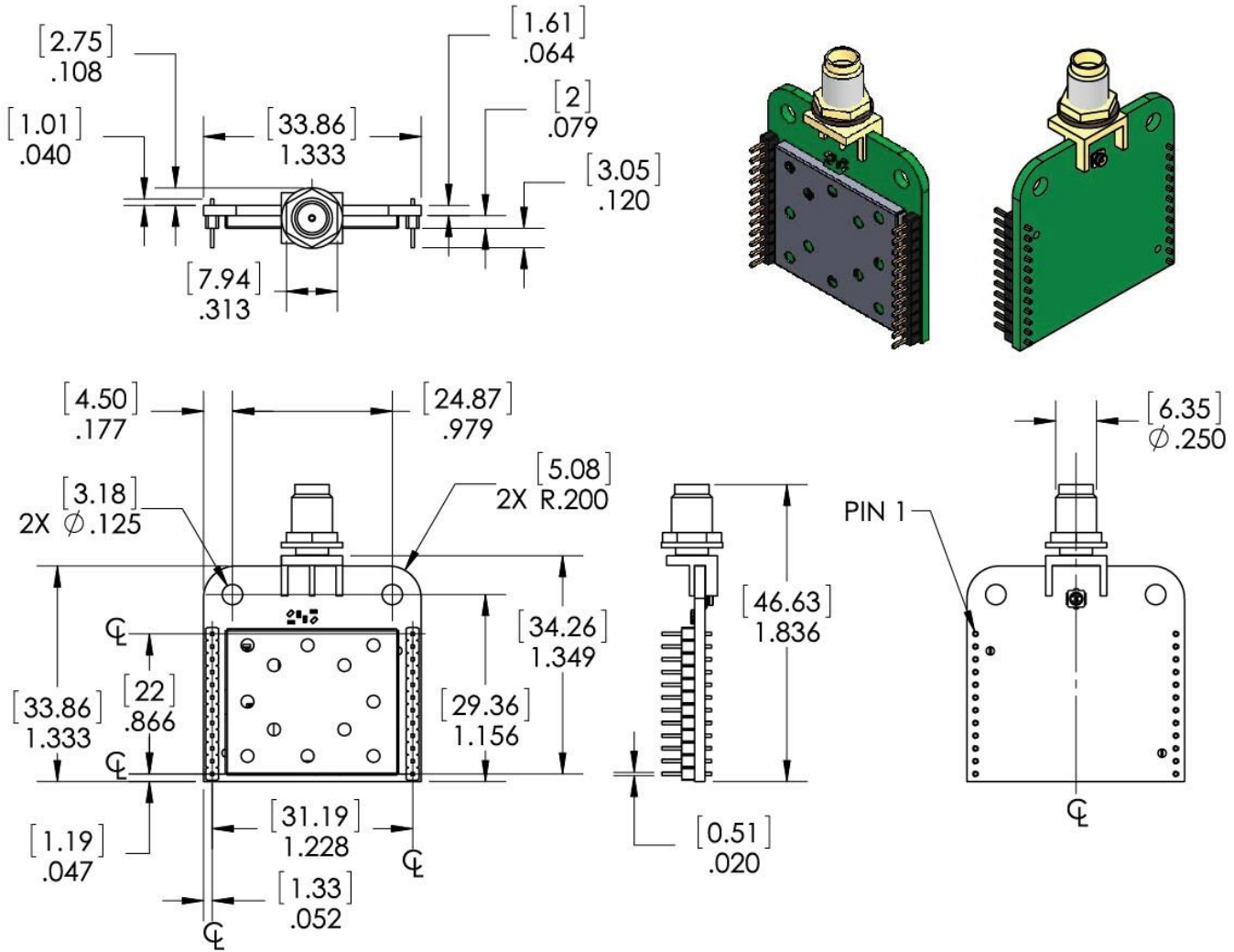

Figure 1.1: RF220SU Mechanical Drawing

NOTE: The area under the module's antenna (marked KEEP OUT AREA) should have no components, no traces, and no copper on any layer of the printed circuit board.

³ Each differential analog input maybe as high as 3.3Vbut the single-ended voltage is still limited to the voltage reference.

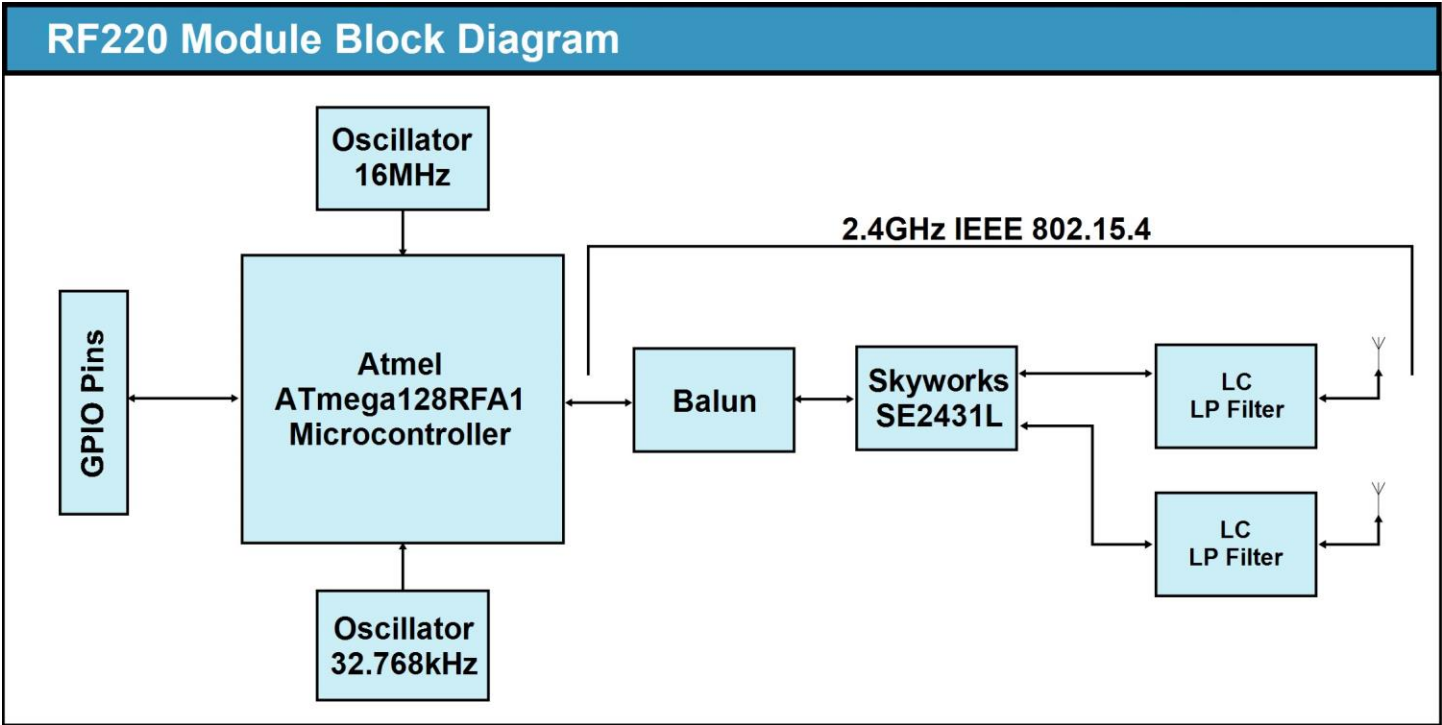

Figure 1.2: Block diagram showing the major subsystems comprising Model RF220SU

Selecting an Antenna

The **RF220SU** uses the RP-SMA connector by default. If you wish to use an external U.FL antenna with your application, you will need to set bit 0x0010 of NV ID 64 to 1 and reboot your node. This is a one-time change that will persist through reboots and program changes. To revert to the RP-SMA antenna, change bit 0x0010 of NV ID 64 back to 0 and reboot the node.

Antenna Gain Performance

NOTE: Antenna gain performance information is based on information from the individual companies at the time this document's release. For added assurance, it's best to obtain antenna performance information directly from that antenna's manufacturer.

NOTE: A u.fl to SMA cable is included for use of the u.fl port.

HyperLink Technologies HG2405RD-RSP

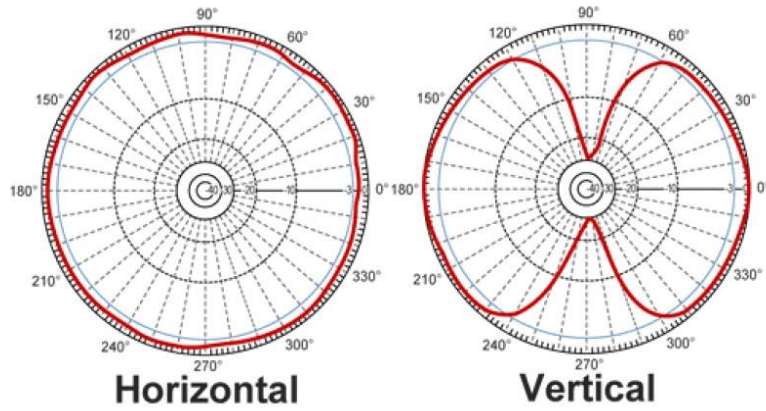
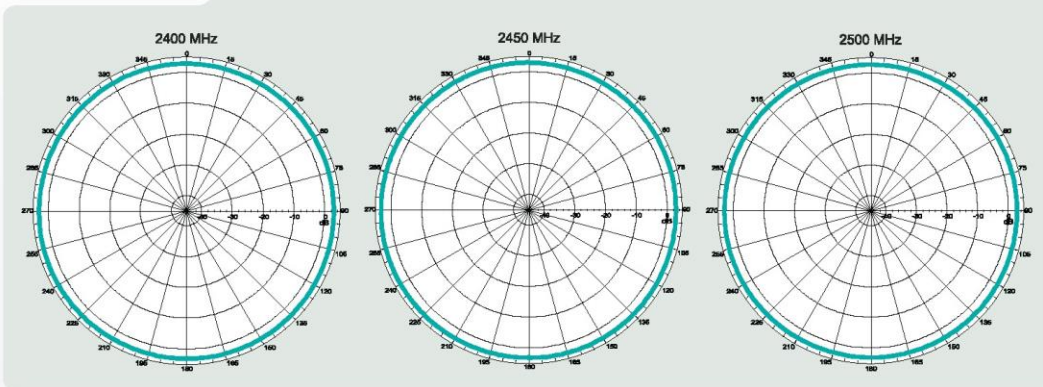

Figure 1.3: HyperLink Technologies HG2405RD-RSP Antenna Gain Performance

Pulse W1027

Horizontal Position



Vertical Position

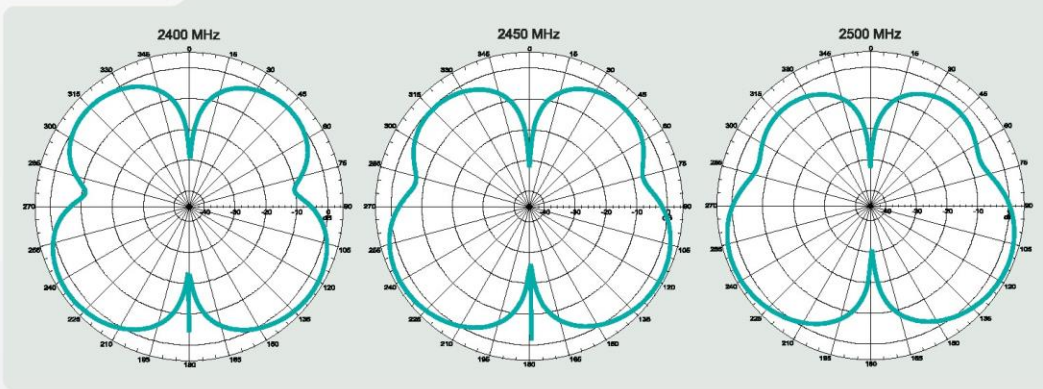

Figure 1.4: Pulse W1027 Antenna Gain Performance

Agency Certifications

United States (FCC)

The Model RF220 modules comply with Part 15 of the FCC rules and regulations. Compliance with the labeling requirements, FCC notices, and antenna usage guidelines is required. In order to comply with FCC Certification requirements, the Original Equipment Manufacturer (OEM) must fulfill the following requirements.

1. The system integrator must place an exterior label on the outside of the final product housing the RF220 Modules. **FCC Label on page 8** shows the contents that must be included on this label.
2. RF220 Modules may only be used with the antenna that has been tested and approved for use with the module. Please refer to the antenna table provided in this section.

OEM Labeling Requirements

NOTICE: The OEM must make sure that FCC labeling requirements are met. This includes a clearly visible exterior label on the outside of the final product housing that displays the contents shown in **FCC Label on page 8**.

MANUFACTURERSNAME BRANDNAME or TRADENAME Contains FCC ID: U9O-RF220SU This device complies with Part 15 of the FCC Rules. Operation is subject to the following two conditions: (1) This device may not cause harmful interferences, and (2) this device must accept any interference received, including interference that may cause undesired operation.

Figure 1.5: FCC Label

FCC Notices

WARNING: The RF220 modules have been tested by the FCC for use with other products without further certification (as per FCC Section 2.1091). Changes or modifications to this device not expressly approved by Synapse Wireless Inc. could void the user’s authority to operate the equipment.

NOTICE: OEM’s must certify final end product to comply with unintentional radiators (FCC Sections 15.107 and 15.109) before declaring compliance of their final product to Part 15 of the FCC Rules.

NOTICE: The RF220 modules have been certified for remote and base radio applications. If the module will be used for portable applications as defined by the FCC, the device must undergo SAR testing.

This equipment has been tested and found to comply with the limits for a Class B digital device, pursuant to Part 15 of the FCC Rules. These limits are designed to provide reasonable protection against harmful interference in a residential installation. This equipment generates, uses, and can radiate radiofrequency energy, and if not installed and used in accordance with the instructions, may cause harmful interference to radio communications. However, there is no guarantee that interference will not occur in a particular installation.

If this equipment does cause harmful interference to radio or television reception, which can be determined by turning the equipment off and on, the user is encouraged to try to correct the interference by one or more of the following measures:

- Reorient or relocate the receiving antenna.
- Increase the separation between the equipment and receiver.
- Connect the equipment into an outlet on a circuit different from that to which the receiver is connected.
- Consult the dealer or an experienced radio/TV technician for help.

FCC Approved Antennas

The RF220SU modules are FCC-approved for fixed base station and mobile applications.

Notice: To reduce potential radio interference to other users, the antenna type and its gain should be chosen so that the equivalent isotropically radiated power (EIRP) is not more than that permitted for successful communication. This module has been designed to operate with the antennas listed in **RF220SU Approved FCC Antennas** on page 9.

The required antenna impedance is 50 ohms.

Table 1.5: RF220SU Approved FCC Antennas

Part Number	Type	Gain	Impedance	Application	Min. Separation
Pulse W1027	Dipole (quarter-wave RPSMA)	3.2 dBi	50Ω	Fixed/Mobile	20 cm.
HyperLink HG2405RD-RSP	Dipole (quarter-wave RPSMA)	5.5 dBi	50Ω	Fixed/Mobile	20 cm.

For more information on approved antennas, please consult the manufacturer's website.

WARNING: RF Exposure: This equipment complies with FCC radiation exposure limits set forth for an uncontrolled environment. This equipment should be installed and operated with minimum distance 20 cm between the radiator and your body. This transmitter must not be co-located or operating in conjunction with any other antenna or transmitter.

NOTICE: The preceding statement must be included as a CAUTION statement in OEM product manuals in order to alert users of FCC RF exposure compliance.

NOTE: Antenna and transmitters may be co-located or operated in conjunction with this device only if the transmitters do not simultaneously transmit. Otherwise, additional regulatory requirements will apply.

Canada (IC)

This device complies with Industry Canada license-exempt RSS standard(s). Operation is subject to the following two conditions: (1) this device may not cause interference, and (2) this device must accept any interference, including interference that may cause undesired operation of the device.

Le présent appareil est conforme aux CNR d'Industrie Canada applicables aux appareils radio exempts de licence. L'exploitation est autorisée aux deux conditions suivantes : (1) l'appareil ne doit pas produire de brouillage, et (2) l'utilisateur de l'appareil doit accepter tout brouillage radioélectrique subi, même si le brouillage est susceptible d'en compromettre le fonctionnement.

Under Industry Canada regulations, this radio transmitter may only operate using an antenna of a type and maximum (or lesser) gain approved for the transmitter by Industry Canada. To reduce potential radio interference to other users, the antenna type and its gain should be so chosen that the equivalent isotropically radiated power (EIRP) is not more than that necessary for successful communication.

Conformément à la réglementation d'Industrie Canada, le présent émetteur radio peut fonctionner avec une antenne d'un type et d'un gain maximal (ou inférieur) approuvé pour l'émetteur par Industrie Canada. Dans le but de réduire les risques de brouillage radioélectrique à l'intention des autres utilisateurs, il faut choisir le type d'antenne et son gain de sorte que la puissance isotrope rayonnée équivalente (p.i.r.e.) ne dépasse pas l'intensité nécessaire à l'établissement d'une communication satisfaisante.

This radio transmitter Model: RF220SU, IC:7084A-RF220SU has been approved by Industry Canada to operate with the listed antenna types with the maximum permissible gain and required antenna impedance for each antenna type indicated. Antenna types not included in this list, having a gain greater than the maximum gain indicated for that type, are strictly prohibited for use with this device.

Le présent émetteur radio Model: RF220SU, IC: 7084A-RF220SU a été approuvé par Industrie Canada pour fonctionner avec les types d'antenne énumérés ci-dessous et ayant un gain admissible maximal et l'impédance requise pour chaque type d'antenne. Les types d'antenne non inclus dans cette liste, ou dont le gain est supérieur au gain maximal indiqué, sont strictement interdits pour l'exploitation de l'émetteur.

Table 1.6: RF220SU Approved IC Antennas

Part Number	Type	Gain	Application	Min. Separation
Pulse W1027	Dipole (quarter-wave RPSMA)	3.2 dBi	Fixed/Mobile	20 cm.
HyperLink HG2405RD-RSP	Dipole (quarter-wave RPSMA)	5.5 dBi	Fixed/Mobile	20 cm.

CE Approved Antennas

The **RF220SU-EU** modules are CE-approved for fixed base station and mobile applications.

Notice: To reduce potential radio interference to other users, the antenna type and its gain should be chosen so that the equivalent isotropically radiated power (EIRP) is not more than that permitted for successful communication. This module has been designed to operate with the antennas listed in Tables 1 and 2. The required antenna impedance is 50 ohms.

Table 1.7: RF220SU-EU Approved CE Antennas

Part Number	Type	Gain	Application	Min. Separation
Pulse W1027	Dipole (quarter-wave RPSMA)	3.2 dBi	Fixed/Mobile	20 cm.

Part Number	Type	Gain	Application	Min. Separation
HyperLink HG2405RD-RSP	Dipole (quarter-wave RPSMA)	5.5 dBi	Fixed/Mobile	20 cm.

For more information on approved antennas, please consult the manufacturer’s website.

NOTE: Antenna and transmitters may be co-located or operated in conjunction with this device only if the transmitters do not simultaneously transmit. Otherwise, additional regulatory requirements will apply.

IC OEM Labeling Requirements

Labeling requirements for Industry Canada are similar to those of the FCC. A clearly visible label on the outside of the final product housing must display the contents shown in **IC Label on page 11**.

MANUFACTURERSNAME
 BRANDNAME or TRADENAME
 MODEL:
 Contains IC: 7084A-RF220SU

Figure 1.6: IC Label

NOTE: The OEM can choose to implement a single label combined for both FCC and IC labeling requirements. If a combined single label is chosen, there must be a clearly visible label on the outside of the final product housing displaying the contents shown in **Combined FCC and IC Label on page 11**.

MANUFACTURERSNAME
 BRANDNAME or TRADENAME
 Contains FCC ID: U90-RF220SU
 Contains IC: 7084A-RF220SU
 This device complies with Part 15 of the FCC Rules. Operation is subject to the following two conditions: (1) This device may not cause harmful interferences, and (2) this device must accept any interference received, including interference that may cause undesired operation.

Figure 1.7: Combined FCC and IC Label